

The PBN AIMA3000 RRAQ series advanced quad return-path receivers are designed for multi-services operators to increase network-return capacities for the ever-growing data and voice bandwidth, while minimizing physical headend space and power requirements.

The RRAQ, as a key element of the AIMA3000 platform, is designed to plug into PBN's next-generation Advanced Intelligent Multi-Service Headend Platform (AIMA3000). The RRAQ-RG is specially designed to accommodate low optical input down to -28dBm and is suitable for RFoG application specified under SCTE-174. The RRAQ-RG incorporates four independent optical return-path receivers that operate at a wavelength between 1260~1620 nm. This density allows up to 64 independent receivers in a 4RU rack space. The user can set each receiver individually for operation in either manual gain control (MGC) mode. The unit hosts low-noise and high-performance amplifiers to ensure good signal-to-noise as well as low distortion. The RRAQ-RG is backward-compatible to RFoG ONU (R-ONU) as well as PBN micro nodes DPON. With high RF outputs, the RRAQ-RG is flexible for various headend configurations.

The RRAQ can be controlled through a netbook or laptop connected to one of the Ethernet ports on the AIMA3000's ASMM module. The RRAQ can also be conveniently monitored and controlled by a PDA via a USB connection to the ASMM. Remote control and monitoring by network operating centers is possible via SNMP and HTTP.

All module settings are retained in memory to ensure trouble-free operation. Furthermore, bulk updating, automatic uploading and downloading of configuration files and NMS Web-based Management system are available for this module.

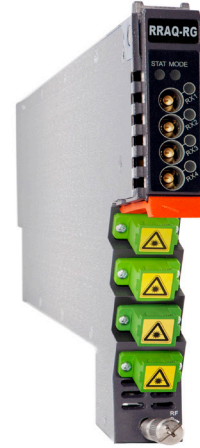

Key Features and Functions

- Bandwidth 5 ~ 85 MHz for future DOCSIS frequency band
- RF output 104 dBμV @ -22 dBm optical input and 30% OMI
- 1260 ~ 1620 nm operating wavelength, to suit CWDM, DWDM and RFoG applications
- Wide optical input from -28dBm to -12dBm.
- Mute function and -6 dB step on individual receivers for ingress control
- 19-inch 4RU chassis supports up to 16 Application Modules
- A single RRAQ module has 4 optical inputs; the full chassis supports up to 64 channels
- Redundancy feature supports modules in the same or different chassis
- Fast switching time of less than 15 ms ensures zero interruption to the network
- Remote status monitoring of connected PBN optical nodes
- Bulk updates, auto upload/download of configuration files
- Real-time alarm monitoring
- Remote firmware upgrade for ease of maintenance
- Plug-and-play hot-swappable AIMA3000 platform module with four independent return-path receivers
- Easy to install, with blind RF connector plugs
- Independent RF test points for ease of setup and maintenance
- A single receiver consumes less than 2 W
- Fully RoHS and CE compliant

Block Diagram

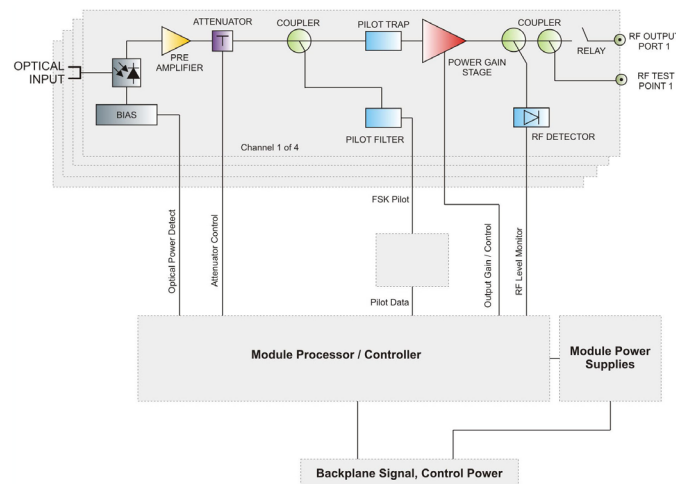

Specifications

Optical Performance

Optical wavelength	1260 nm to 1620 nm
Optical inputs	-28 dBm to -12 dBm
Optical connectors	4 x SC/APC ⁽¹⁾ , E2000/APC, FC/APC

RF Performance

RF bandwidth	5 MHz to 85 MHz (RRAQ RFoG option)
RF output level ⁽²⁾	104 dBµV@-22dBm optical input 30%OMI
RF flatness	± 0.75 dB
Gain adjustment	52 dB
RF impedance	75 Ω
RF return loss	> 16 dB
Receiver isolation	> 60 dB

RF test point relative to RF output port	-20 dB ± 1 dB
RF OUT connectors	4 x GSK-type female
RF test points	4 x Mini-SMB
Alarms and status	Front-panel LEDs, SNMP traps
Equivalent Input Noise Current	4 pA/sqr(Hz)

Link Performance

CNR ⁽³⁾	> 38 dB
IMD2 ⁽⁴⁾	> 47 dB
NPR (@ -22dBm)	> 30 dB (over 10dB dynamic range)

General

Power supply	Powered via AIMA3000 backplane
Power consumption	< 8 W
Operating temperature	0°C to +50°C
Storage temperature	-20°C to +70°C
Dimensions (WxDxH)	24.6 x 410 x 152.5 mm
Weight	0.87 kg
Network management	NMS3 via AIMA3000 ASMM

Notes

- (1) Standard option. Contact a PBN Sales Representative for availability of other options.
- (2) Measured in a typical system with -22 dBm optical input, 30% OMI, gain setting adjusted to maximum (the stated RF output level does not necessarily apply with other optical input levels).
- (3) Measured @ -15 dBm, 6% OMI, 4 channels
- (4) Measured @ -15dBm, 6% OMI, 4 channels

Order Details

AIMA-RRAQ-RG-[X] | Return Receiver Analog Quad Module

Options:

RG	Version
	RG(RFoG) Low-noise RFoG
X	Optical Connector Type
	S SC/APC *
	E E2000/APC
	F FC/APC

* Standard option. Contact a PBN Sales Representative for availability of other options.

